

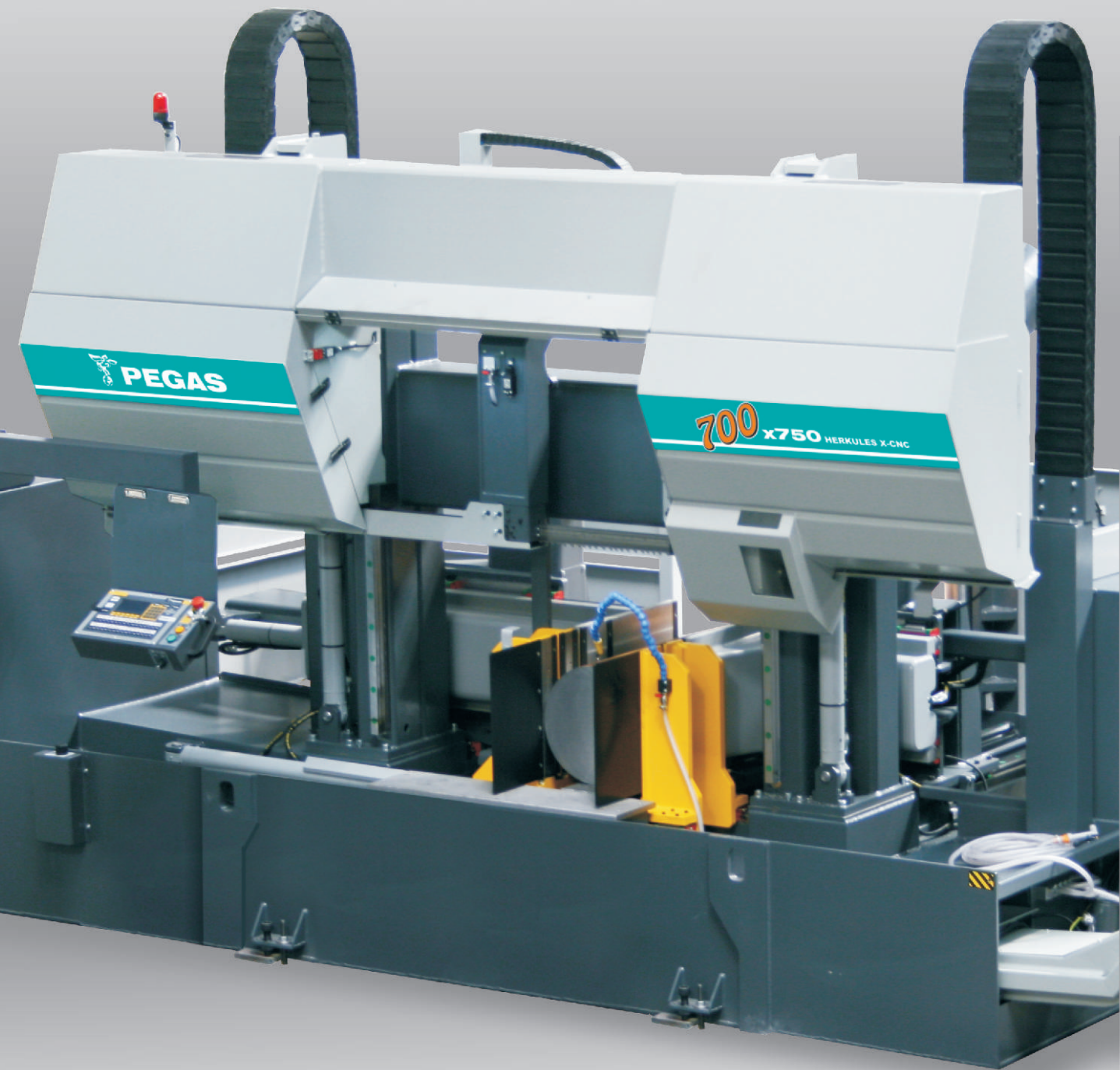

**700x750
HERKULES X-CNC**

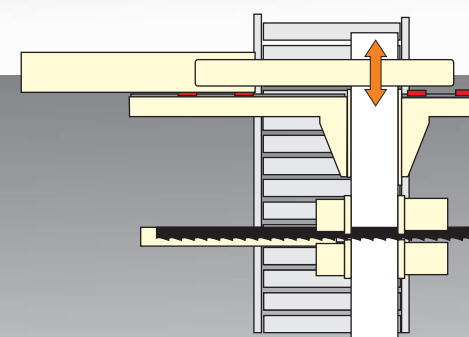

**700x750
HERKULES X-CNC**

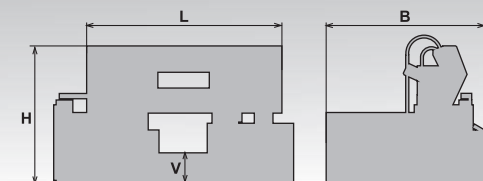
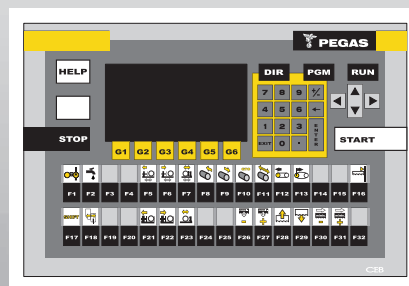

700	700*	750x700	750x450

●	3x400V 50 Hz	11,0	15-80	7680x67x1,6	12 500

Lmin	Lmax	B	Hmin	Hmax	V
4800	7000	2750	2300	2700	615

*doporučené hodnoty /recommended values

700x750 HERKULES X-CNC

700 RBRS +RBR

700 RBR

700 V +RDT

700 DMV 1000

700 HPV

700 HP-A

OZP-L 2000

OZD-L 2000

OZS-D 2000 +RDM

OZP-D 2000 +RDT

700 RDT 2000/750

700 RDT 1000/750

700 VTH

OZS 2000 +RDM

OZP 2000 +RDT

700 RBR

700 DMV 2000

700 LSG

700 RDM 2000/750

700 RDRS

700 TDM 2000/750

700 TDT 2000/750

700 TDML 2000/750 +TDM 2000/750

BOX-TAH

BOX-TRI

700 RDML 2000/750 +RDM 2000/750

OPTION

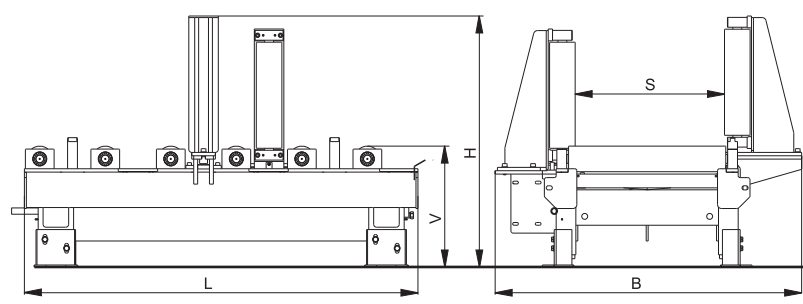

	L [mm]	V [mm]	H [mm]	S [mm]	B [mm]			
RDT	1000 2000	615 615	1275 1275	750 750	1560 1560	3 6	2000 2000	500 800
RDM	2000	615	1275	750	1560	6	2000	1700
RDML	2000	615	1275	750	1560	6	2000	950

PEGAS-CDC (cutting data calculator)

PEGAS-ABP (automatic band position)

PEGAS-ATB (automatic transport bar)

PEGAS-CMU (contactless movement up)

PEGAS-PKS (Movement of the feeder by the ball screw)

PEGAS-KKR (indication the position of the blade)

MINI LUBE

LASER LINE

CK

PEGAS-ASR (automatic servo regulation)

PEGAS-ARP (automatic cutting feed regulation)

STANDARD OPTION

PEGAS GONDA PEGAS-GONDA s.r.o., Čs. armády 322, 684 01 Slavkov u Brna
 Tel: 00420-544 221 125, 00420-544 221 126, fax: 00420 544 227 389
 E-mail: pegas@gonda.cz, www.pegas-gonda.cz, Czech Republic

- výrobce si vyhrazuje právo provádět změny technických údajů, technické údaje odpovídají 1.9.2011
 /producer has the right to make changes of technical data, technical data are valid on 1.9.2011/
 - pila na fotografii není vždy v základním provedení / the machine in the picture is not always in the basic version
 - uvedené rozměry odpovídají stroji v základním provedení / mentioned diameters are for machine in basic version