

# PEGAS

## 240x280 A-CNC-R-F

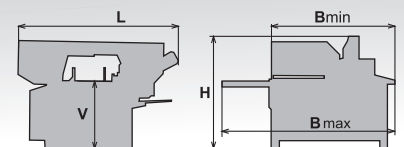
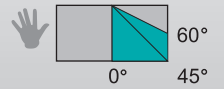

mm	0°	45°	60°	a x b	a x b
	240	190	120	X	X
	150*	110*	80*	X	X
a x b	280x220	190x170	120x150	280x120	230x100
a x b	280x220	150x220	120x150	280x120	230x100

	kW	m/min	mm		kg
3x400V 50 Hz	2,2	20-100	2980x27x0,9		800
L	Bmin	Bmax	Hmin	Hmax	V
2150	1750	2200	1400	1900	940

\*doporučené hodnoty /recommended value



# PEGAS

## 240x280 A-CNC-R-F

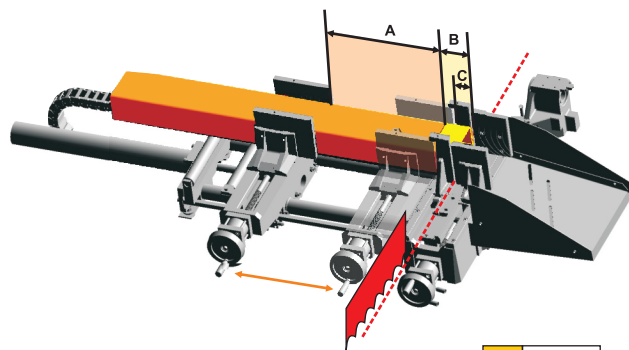

A	515
B	240
C	220

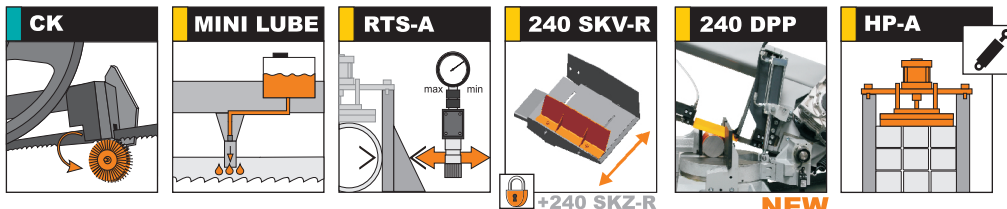

### OPTION

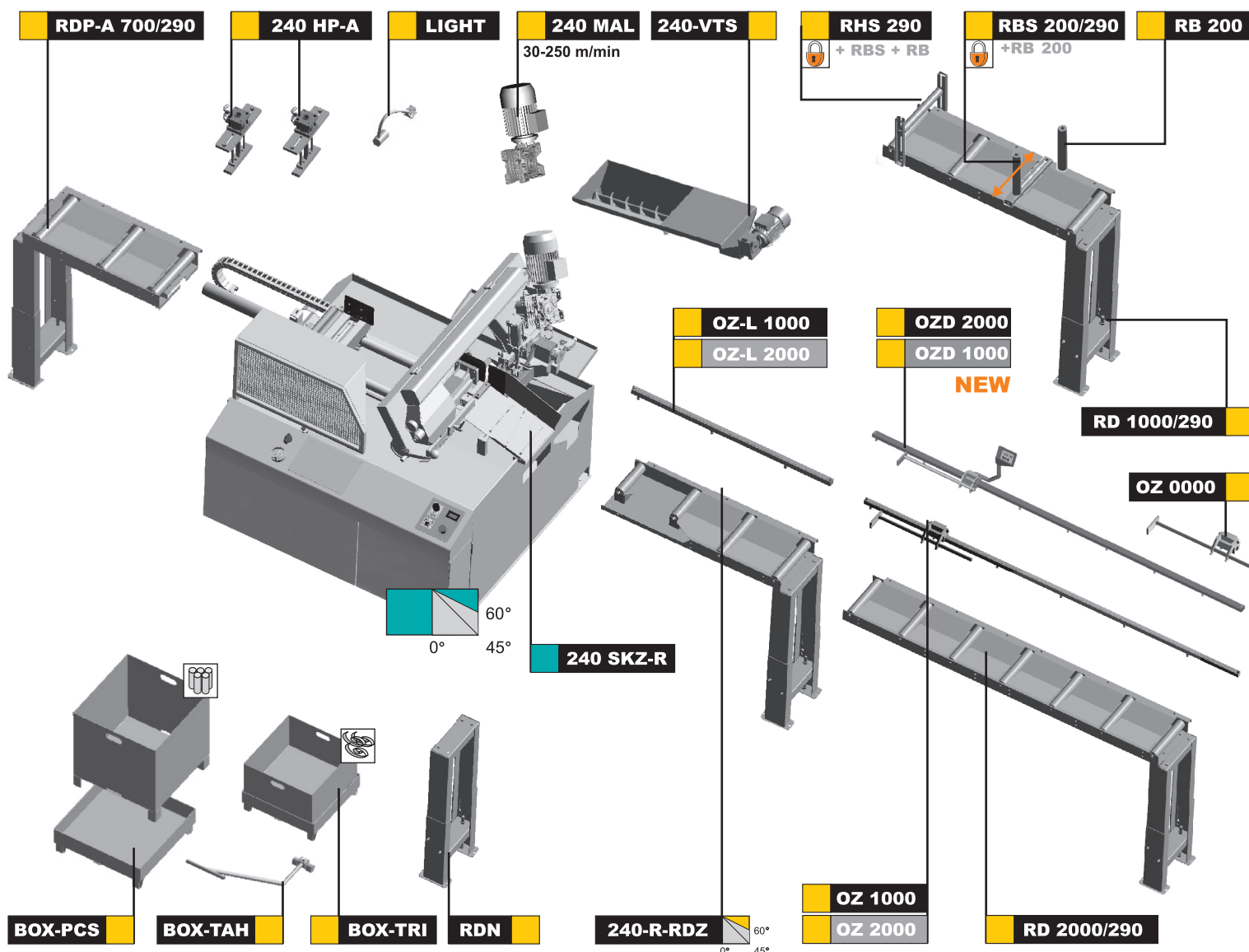

■ STANDARD ■ OPTION



PEGAS-GONDA s.r.o., Čs. armády 322, 684 01 Slavkov u Brna  
 Tel: 00420-544 221 125, 00420-544 221 126, fax: 00420 544 227 389  
 E-mail: pegas@gonda.cz, [www.pegas-gonda.cz](http://www.pegas-gonda.cz), Czech Republic

- výrobce si vyhrazuje právo provádět změny technických údajů, technické údaje odpovídají 1.3.2011  
 /producer has the right to make changes of technical data, technical data are valid on 1.3.2011/  
 - pila na fotografii není vždy v základním provedení / the machine in the picture is not always in the basic version  
 - uvedené rozměry odpovídají stroji v základním provedení / mentioned diameters are for machine in basic version/