

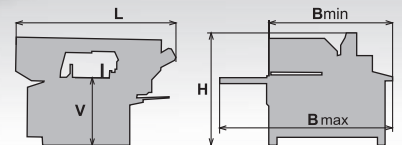

# 290x290 X-CNC-LR-1500-F

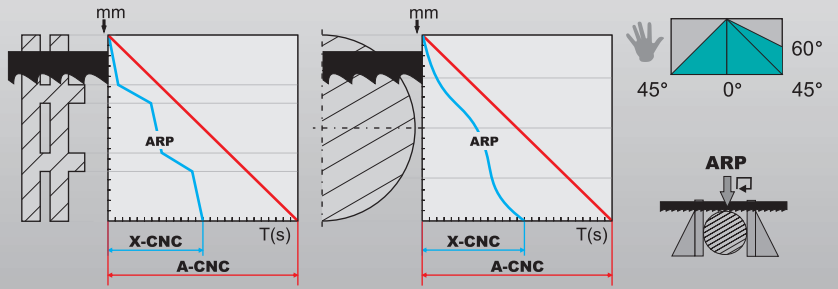
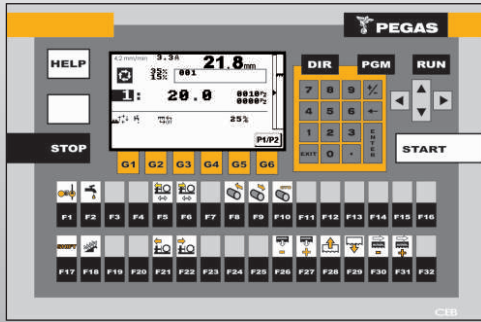

mm	0°	45°**	60°**	45°**	a x b	a x b
	290	240	150	240	X	X
	180*	110*	80*	110*	X	X
a x b	320x290	240x150	150x180	240x100	320x160	230x140
a x b	320x290	210x290	130x290	150x290	320x160	230x140

3x400V 50 Hz	2,2	20-100	3100x27x0,9		1320
L	Bmin	Bmax	Hmin	Hmax	V
1900	3050	4250	1600	2200	940

\*doporučené hodnoty / recommended values  
\*\*pouze v poloautomatickém režimu / only in semiautomatic mode



# PEGAS

## 290x290 X-CNC-LR-1500-F

	mm
A	1515
B	300
C	30

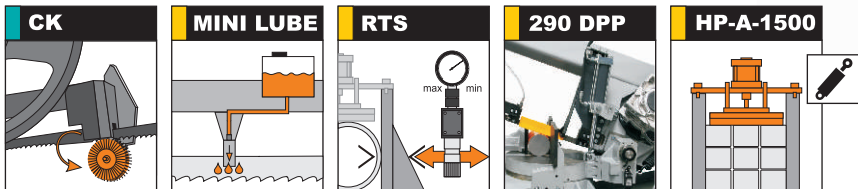
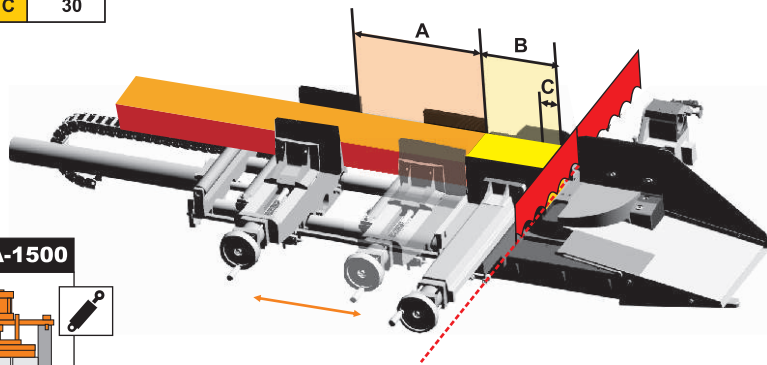

### OPTION

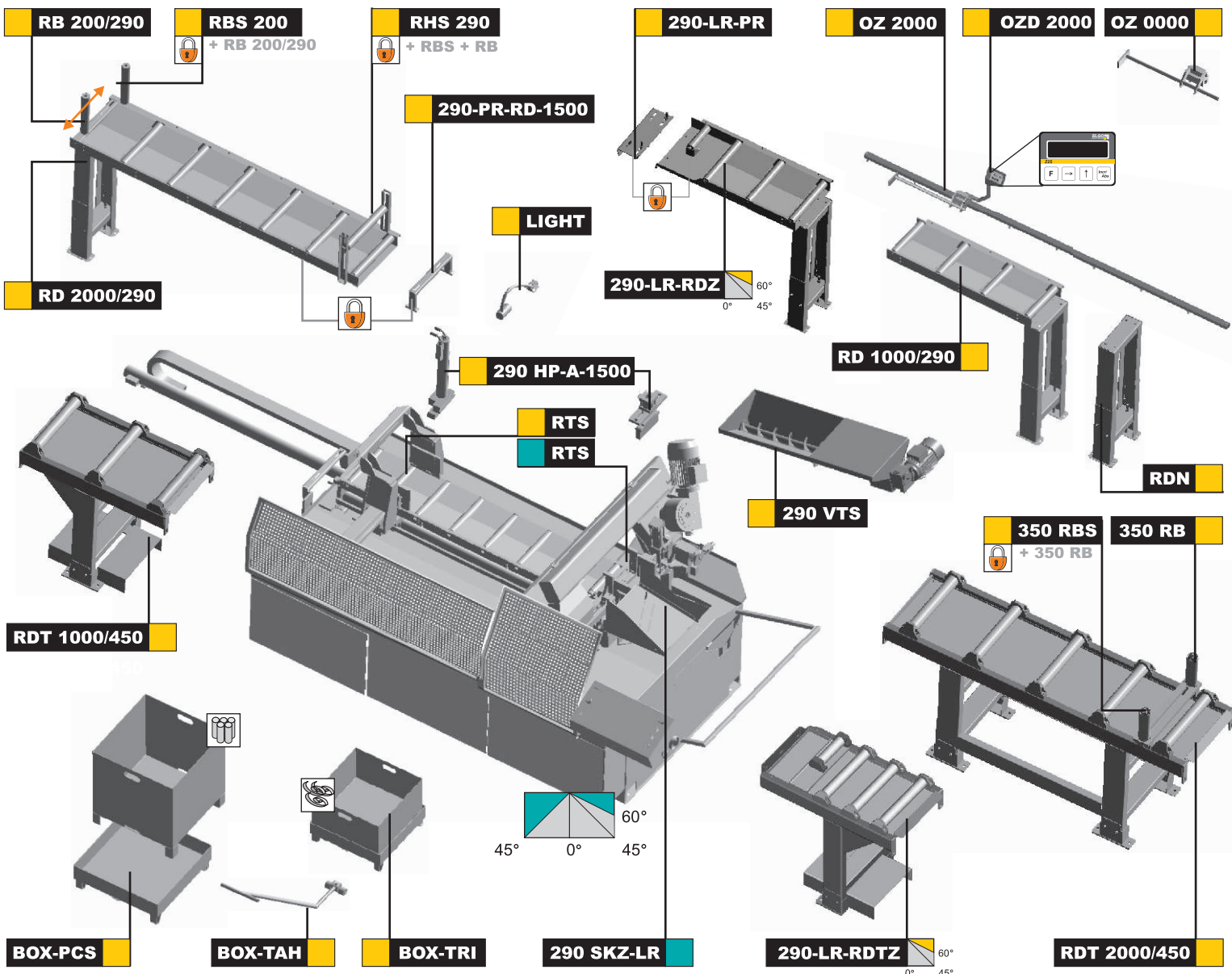

■ STANDARD ■ OPTION



PEGAS-GONDA s.r.o, Čs. armády 322, 684 01 Slavkov u Brna  
 Tel: 00420-544 221 125, 00420-544 221 126, fax: 00420 544 227 389  
 E-mail: pegas@gonda.cz, [www.pegas-gonda.cz](http://www.pegas-gonda.cz), Czech Republic

- výrobce si vyhrazuje právo provádět změny technických údajů, technické údaje odpovídají 1.1.2012  
 /producer has the right to make changes of technical data, technical data are valid on 1.1.2012/  
 - píla na fotografiích není vždy v základním provedení /the machine in the picture is not always in the basic version  
 - uvedené rozměry odpovídají stroji v základním provedení /mentioned diameters are for machine in basic version/