

CARBIDE TIPPED BAND TECHNOLOGY

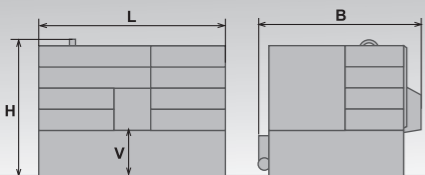

mm	0°	$\frac{b}{a \times b}$
	510	X
	510*	X
	510x510	500x490
	510x510	500x490

3x400V 50 Hz	7,5	20-150 (15-80)	6060x54x1,6		6880
Lmin	B	Hmin	Hmax	V	
3100	2350	2100	2600	800	

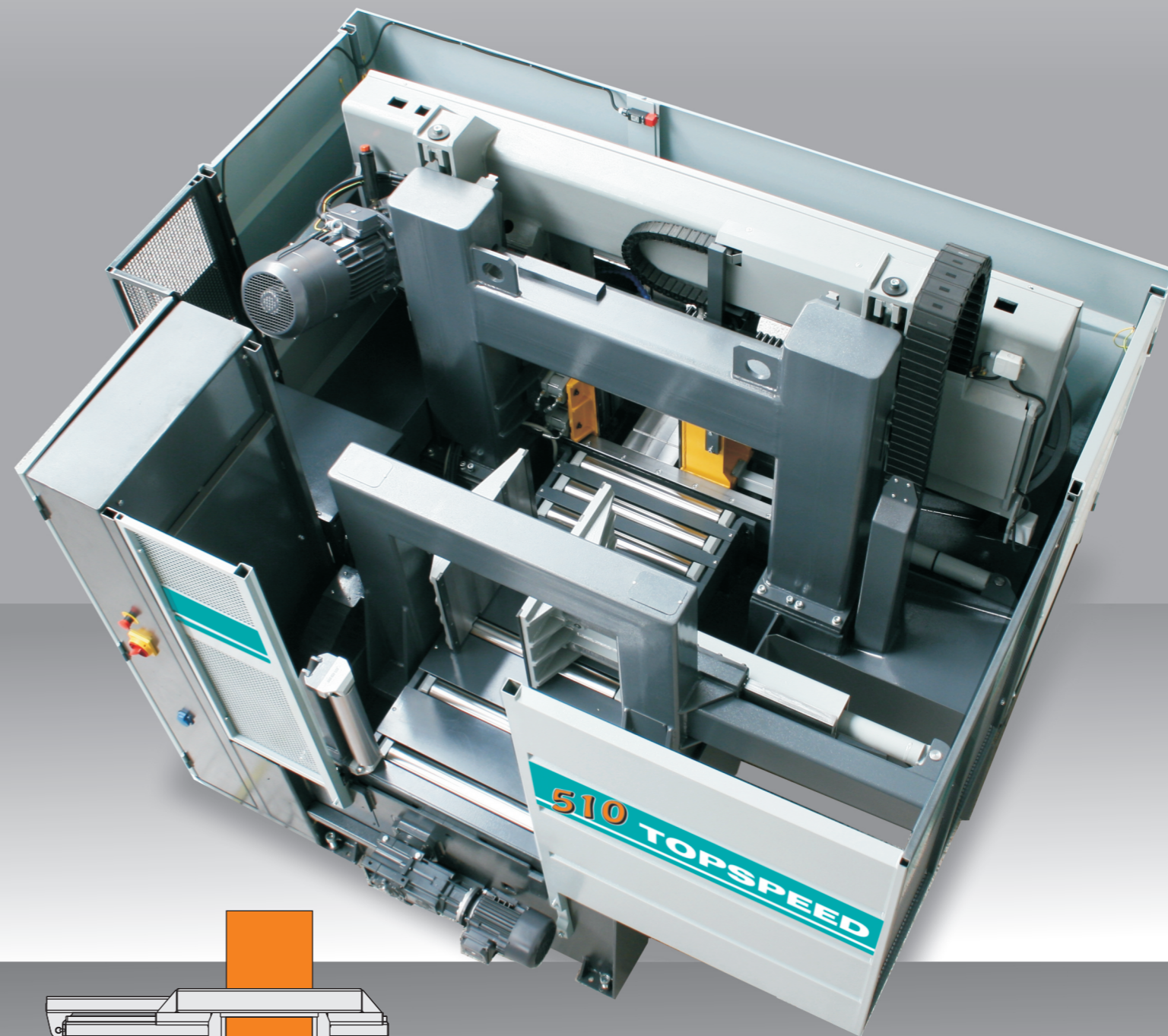
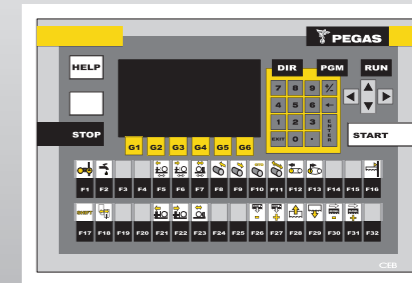
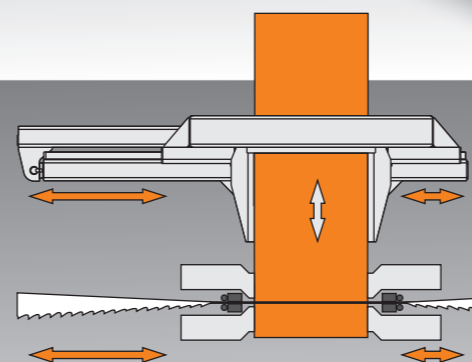

\*doporučené hodnoty/ recommended values



150x200 220x250 240x280 250x315 290x290 290x320 350x400 350x500 440x600 450x600 460x600 500x500 510x510 600 CAMEL 650x750 660x760 850x1000 1200x1400

**500 RDM-E 2000/620** **500 HP-A** **500 RDT 2000/620** **500 RBRS** **500 RBR** **BOX-TAH** **BOX-PCS**

**500 V** **500 VTS** **500 RDT 1000/620** **500 OZP-L 2000** **500 OZD-L 2000** **500 OZS 2000** **500 OZS-D 2000** **500 RDH**

**600 VTH** **500 RDZ+SKZ 2000** **500 OZP 2000** **500 OZP 1000** **500 OZP-D 2000** **500 OZP-D 1000** **500 OZK**

**500 RDM 2000/620** **500 RDML 2000/620** **500 RDML 1000/620**

**OPTION**

	L [mm]	V [mm]	S [mm]			
RDT	2000	790+30	620	5	1700	255
RDM	2000	790+30	620	5	1700	345
RDML	2000	790+30	620	5	1700	300

**PEGAS-ATB (automatic transport bar)**

LASER BAND=CUT

**PEGAS-CDC (cutting data calculator)**

AUTOMATIC:

- m/min
- mm/min
- TPI 2/3

NORM 42CrMoNi5  
D=250 mm

**PEGAS-ABP (automatic band position)**

**PEGAS-CMU (contactless movement up)**

**PEGAS-ASR (automatic servo regulation)**

Carbide tipped band mm/min

**PEGAS-ARP (automatic cutting feed regulation)**

Bimetal band mm T(s)

**CK** **MINI LUBE**

STANDARD OPTION

**PEGAS-GONDA** PLY NA KOV - BAND SAW MACHINES  
 PEGAS-GONDA s.r.o, Čs. armády 322, 684 01 Slavkov u Brna  
 Tel: 00420-544 221 125, 00420-544 221 126, fax: 00420 544 227 389  
 E-mail: pegas@gonda.cz, www.pegas-gonda.cz, Czech Republic

- výrobce si vyhrazuje právo provádět změny technických údajů, technické údaje odpovídají 1.9.2010  
 /producer has the right to make changes of technical data, technical data are valid on 1.9.2010/  
 - pila na fotografii není vždy v základním provedení /the machine in the picture is not always in the basic version  
 - uvedené rozměry odpovídají stroji v základním provedení /mentioned diameters are for machine in basic version