

360x500 GH-LR

360x500 SHI-LR-F

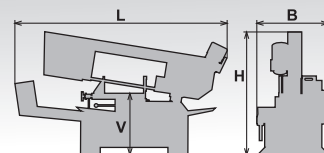
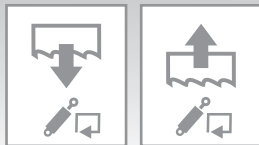
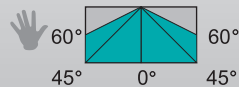

mm	0°	45°	60°	45°	60°	a x b
	360	350	270	360	310	X
	250*	180*	130*	180*	130*	X
a x b	500x360	400x180	270x320	400x190	310x170	500x220
b x a	500x360	350x360	240x360	330x360	200x360	500x220

			mm		kg
3x400V 50 Hz	2,0/2,6*	42/85*	4780x34x1,1		650
L	B	Hmin	Hmax	V	
2750	950	1420	2270	820	

*F=3,0 kW, **20-100 m/min

*doporučené hodnoty /recommended values



PEGAS

360x500 GH-LR 360x500 SHI-LR-F

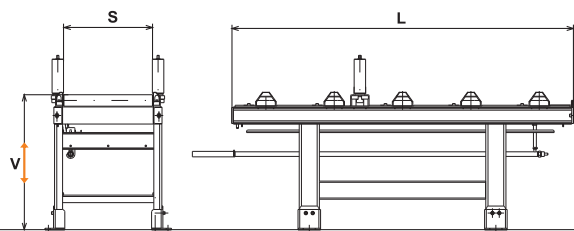

	L [mm]	V [mm]	S [mm]			
RDZ/RDZM	2000	790+30	520	8	1000	300
RDP/RDPM	2000	790+30	520	7	1000	290
RDT	2000	790+30	520	5	1000	255
RDM	2000	790+30	520	5	1000	230
RDML	2000	790+30	520	5	1000	300

OPTION

360 RDP 2000
360 RDPM 2000

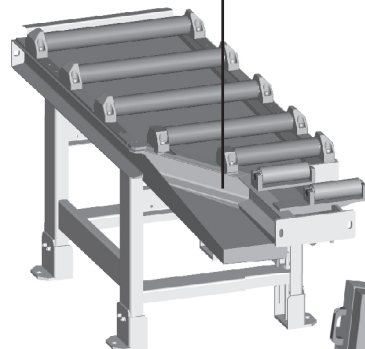

360 RB
360 RBS

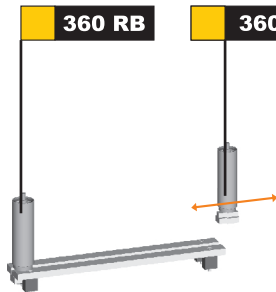

360 SRZ-M +GH
360 SRZ +SHI

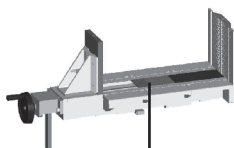

360 V
+RDT

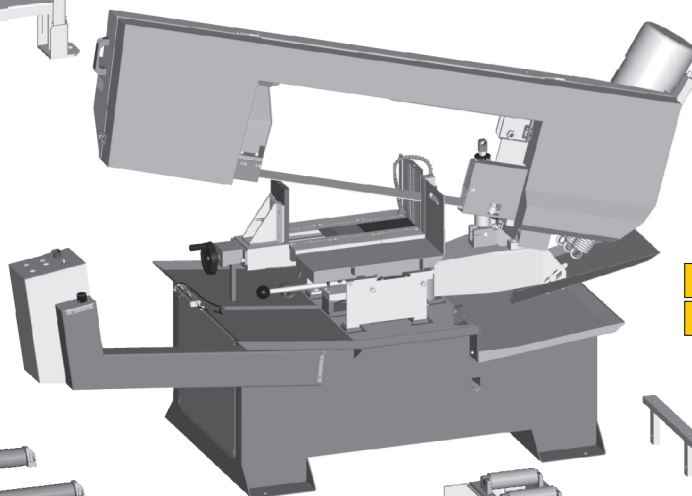
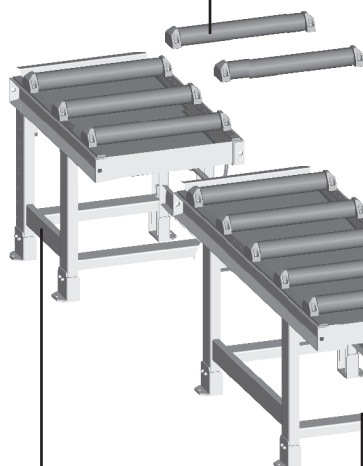

360 MAL
70-140 m/min



360 RDH

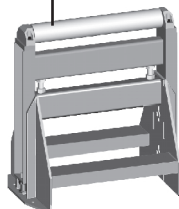

OZP-L 2000
OZD-L 2000

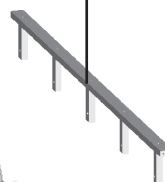

OZS 2000
OZSD 2000 +RDM

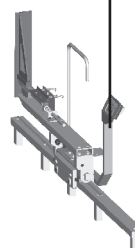

OZP-D 2000
OZP-D 1000

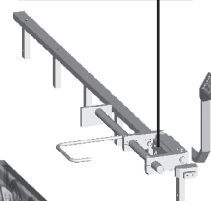

360 RDT 1000/520

360 RDT 2000/520

360 RDM 2000/520

360 RDZ 2000
360 RDZM 2000

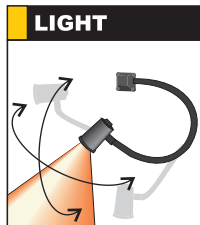
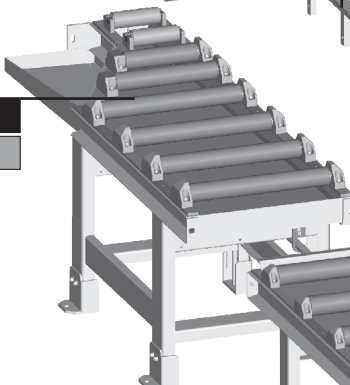

LIGHT

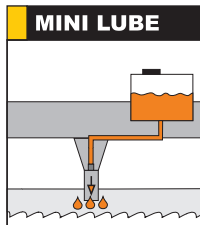

MINI LUBE

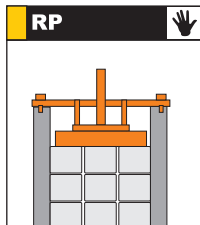

RP

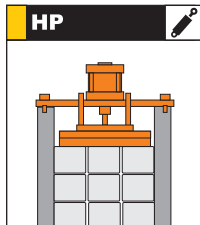

HP

+SHI

360 RDML 2000/520 +RDM

STANDARD OPTION

PEGAS GONDA
PILY NA KOV - BAND SAW MACHINES

PEGAS-GONDA s.r.o., Čs. armády 322, 684 01 Slavkov u Brna
Tel: 00420-544 221 125, 00420-544 221 126, fax: 00420 544 227 389
E-mail: pegas@gonda.cz, www.pegas-gonda.cz, Czech Republic

- výrobce si vyhrazuje právo provádět změny technických údajů, technické údaje odpovídají 1.5.2011
/producer has the right to make changes of technical data, technical data are valid on 1.5.2011/
- pila na fotografii není vždy v základním provedení / the machine in the picture is not always in the basic version
- uvedené rozměry odpovídají stroji v základním provedení / mentioned diameters are for machine in basic version/