

# 350x400 H-A-CNC

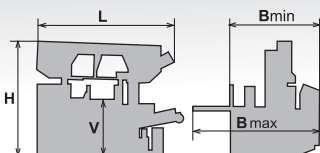
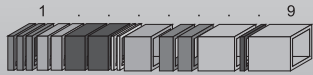
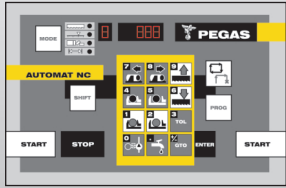

mm	0°	a x b	
	350	X	X
	250*	X	X
a x b	400x350	400x210	400x190
a x b	400x350	400x210	400x190

3x400V 50 Hz	3,0	20-100	4520x34x1,1		1350
L	Bmin	Bmax	Hmin	Hmax	V
2300	1800	2100	2000	2100	930

\*doporučené hodnoty /recommended values



# PEGAS

## 350x400 H-A-CNC

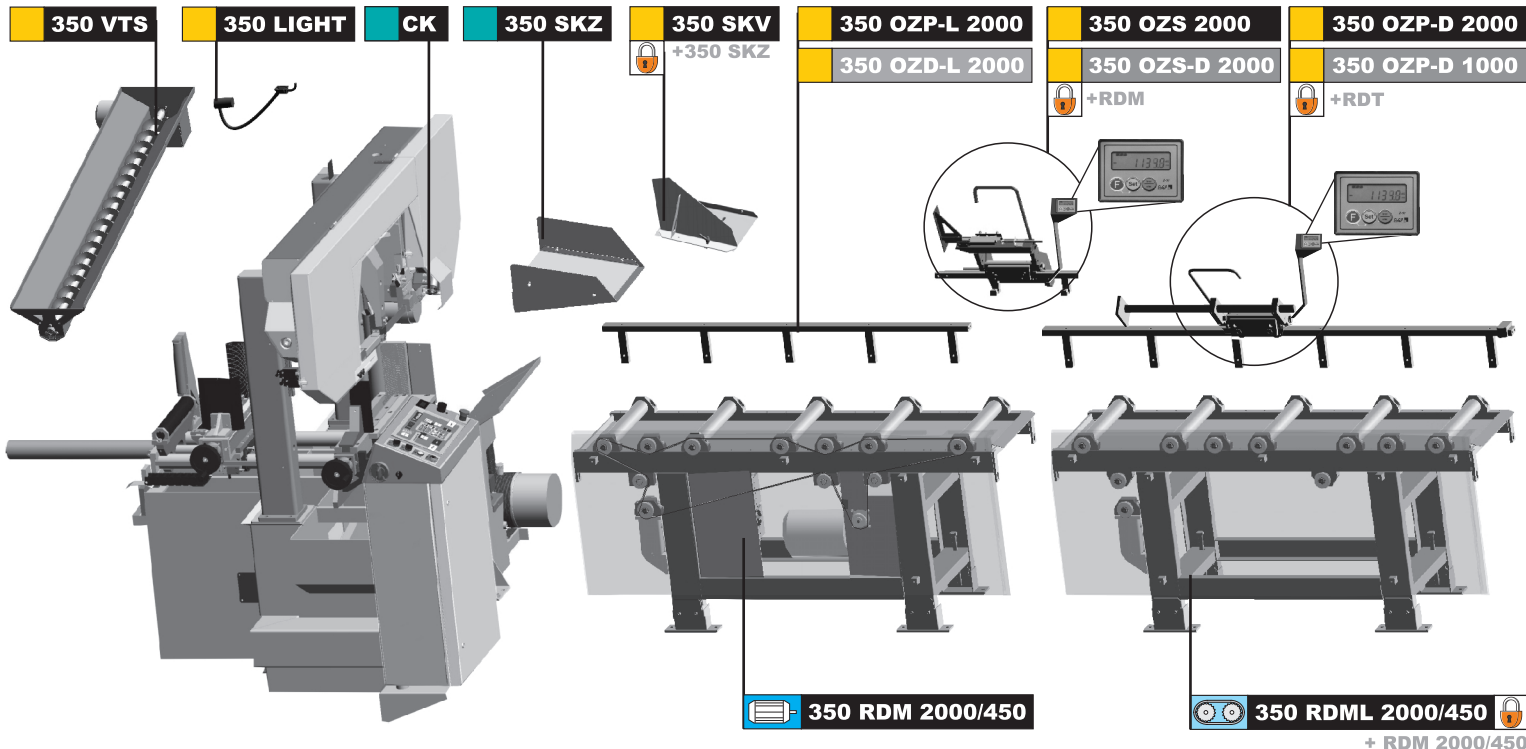
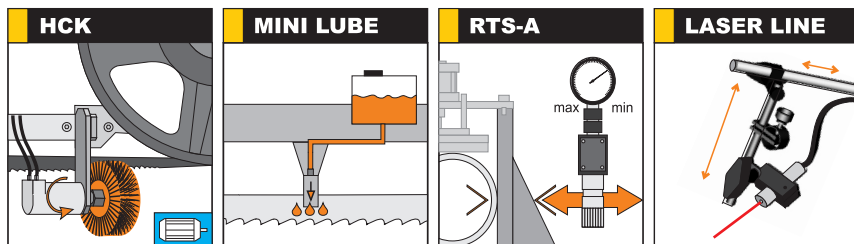

### OPTION

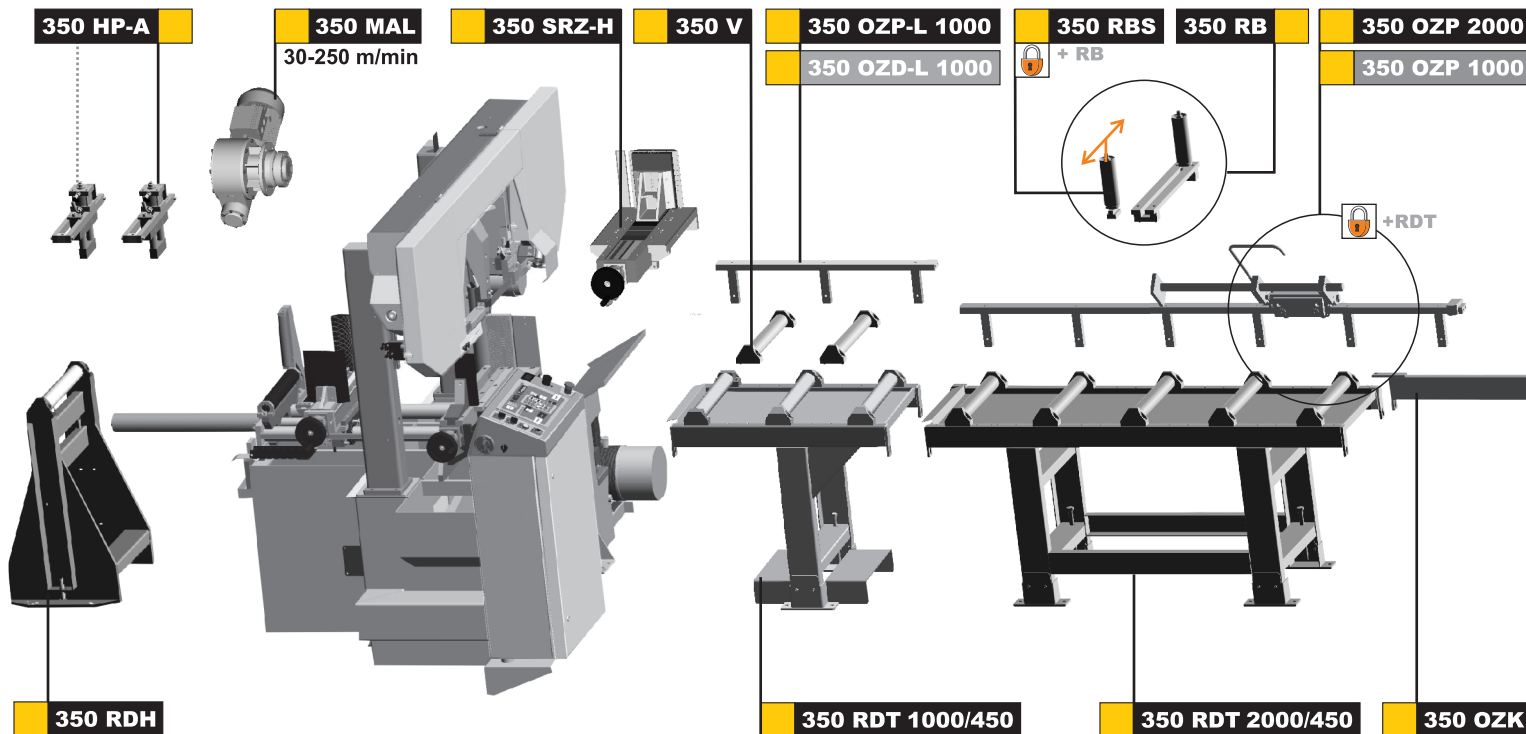

■ STANDARD ■ OPTION



PEGAS-GONDA s.r.o., Čs. armády 322, 684 01 Slavkov u Brna  
 Tel: 00420-544 221 125, 00420-544 221 126, fax: 00420 544 227 389  
 E-mail: pegas@gonda.cz, [www.pegas-gonda.cz](http://www.pegas-gonda.cz), Czech Republic

- výrobce si vyhrazuje právo provádět změny technických údajů, technické údaje odpovídají 1.1.2011  
 /producer has the right to make changes of technical data, technical data are valid on 1.1.2011/  
 - pila na fotografiích není vždy v základním provedení / the machine in the picture is not always in the basic version  
 - uvedené rozměry odpovídají stroji v základním provedení / mentioned diameters are for machine in basic version/