

**350x400 H**  
**350x400 H-X**

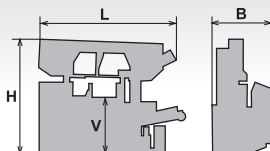
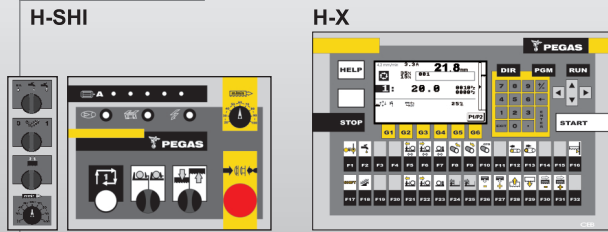

mm	0°	$\begin{matrix} b \\ a \times b \end{matrix}$
	350	X
	250*	X
$\begin{matrix} a & b \\ a & b \end{matrix}$	400x350	400x190
$\begin{matrix} a & b \\ a & b \end{matrix}$	400x350	400x190

3x400V 50 Hz	3,0	20-100	4520x34x1,1		1150
L	B	Hmin	Hmax	V	
2300	1000	2000	2100	930	

\*doporučené hodnoty /recommended values



# PEGAS

## 350x400 H 350x400 H-X

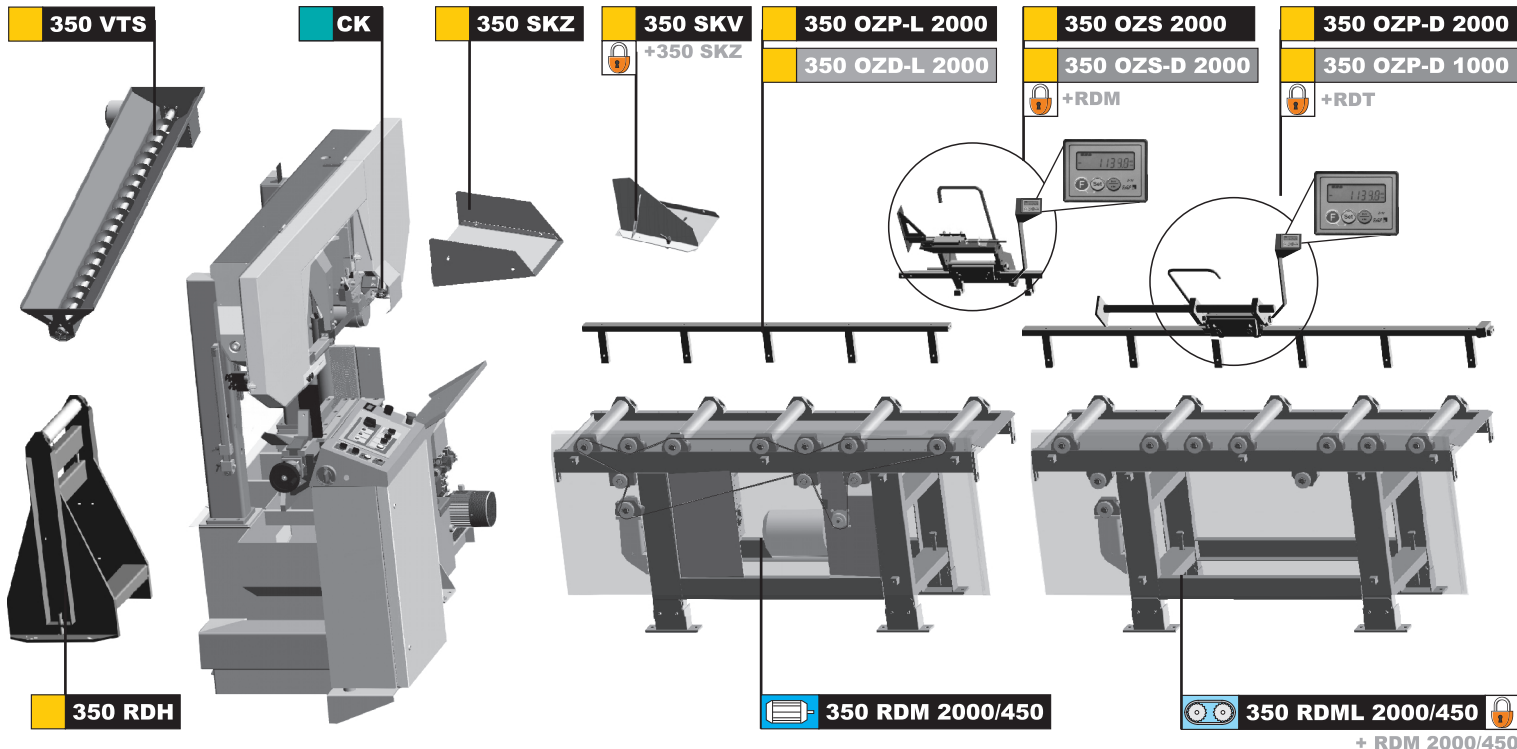
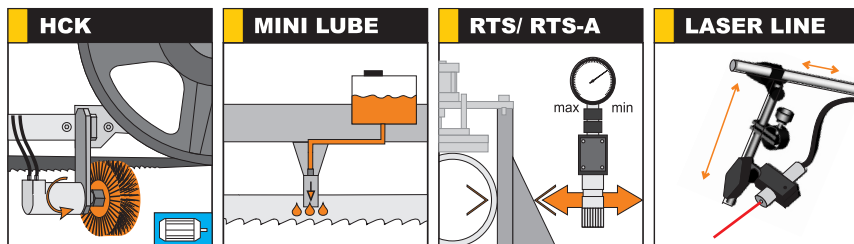

### OPTION

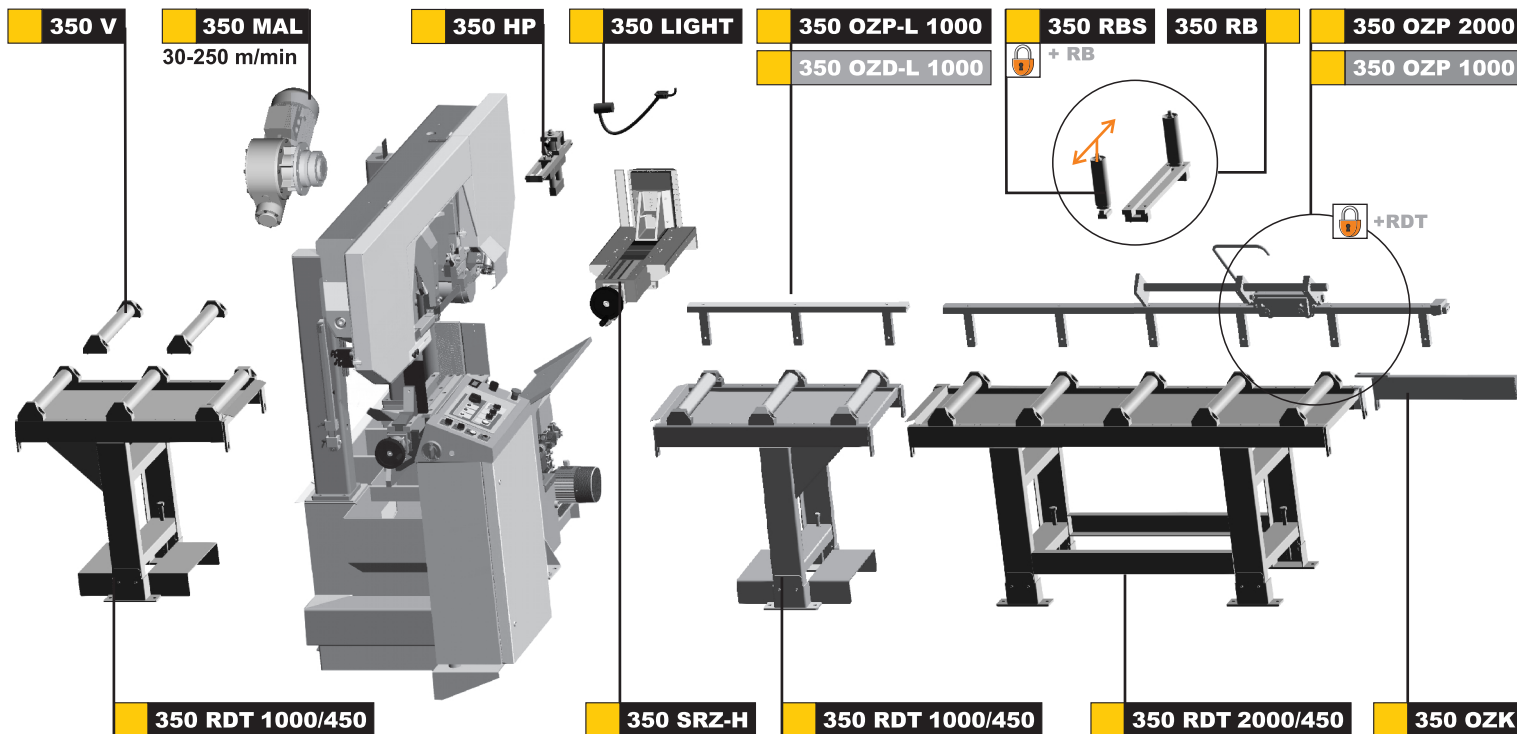

■ STANDARD ■ OPTION



PEGAS-GONDA s.r.o., Čs. armády 322, 684 01 Slavkov u Brna  
 Tel: 00420-544 221 125, 00420-544 221 126, fax: 00420 544 227 389  
 E-mail: pegas@gonda.cz, [www.pegas-gonda.cz](http://www.pegas-gonda.cz), Czech Republic

- výrobce si vyhrazuje právo provádět změny technických údajů, technické údaje odpovídají 1.9.2009  
 /producer has the right to make changes of technical data, technical data are valid on 1.9.2009/  
 - pila na fotografii není vždy v základním provedení / the machine in the picture is not always in the basic version  
 - uvedené rozměry odpovídají stroji v základním provedení / mentioned diameters are for machine in basic version/