

# 1200x1400 HERKULES X

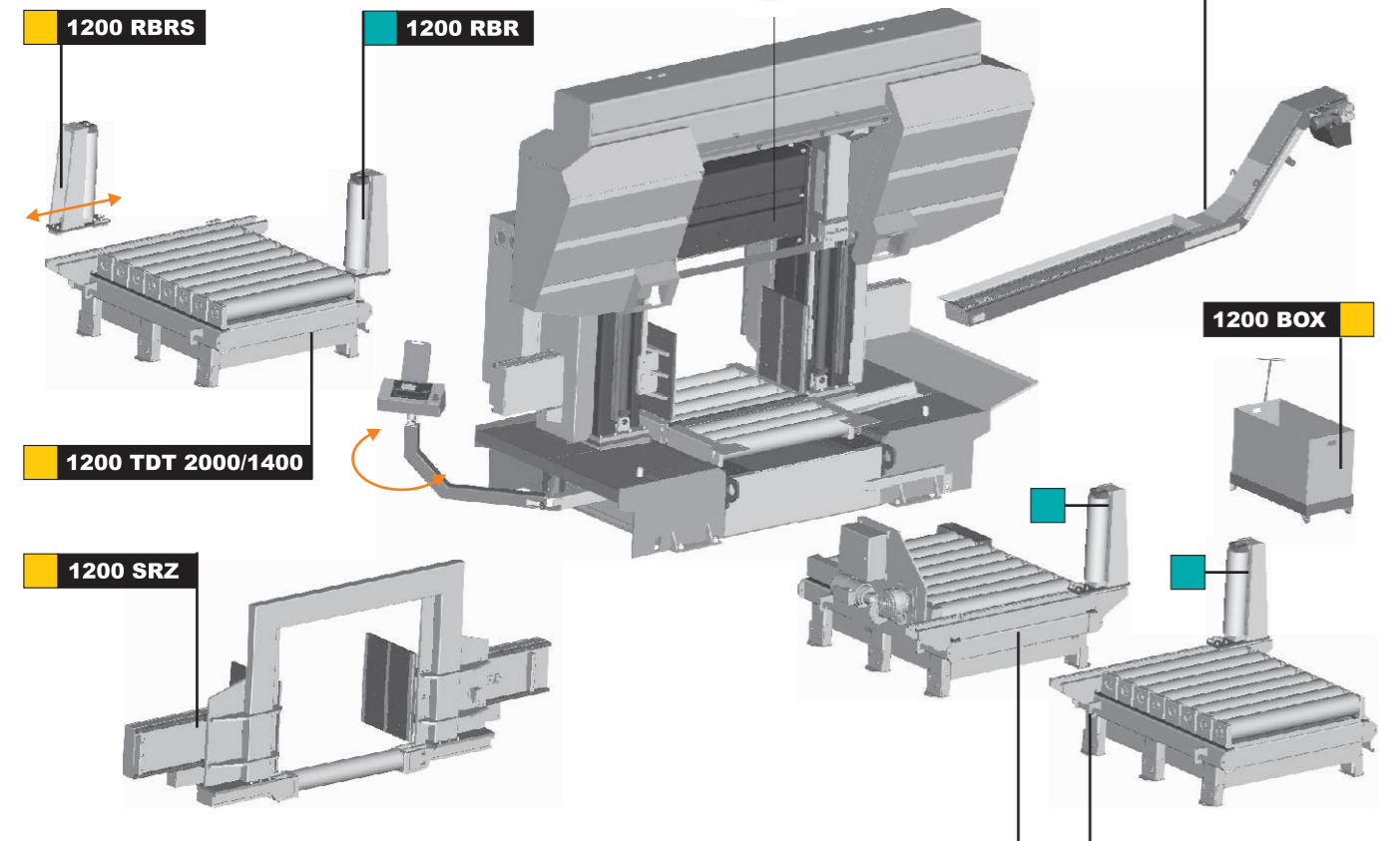

OPTION 1200 TDM 2000/1400 1200 TDML 2000/1400 +TDM 2000/1400

# 1200x1600 GOLEM

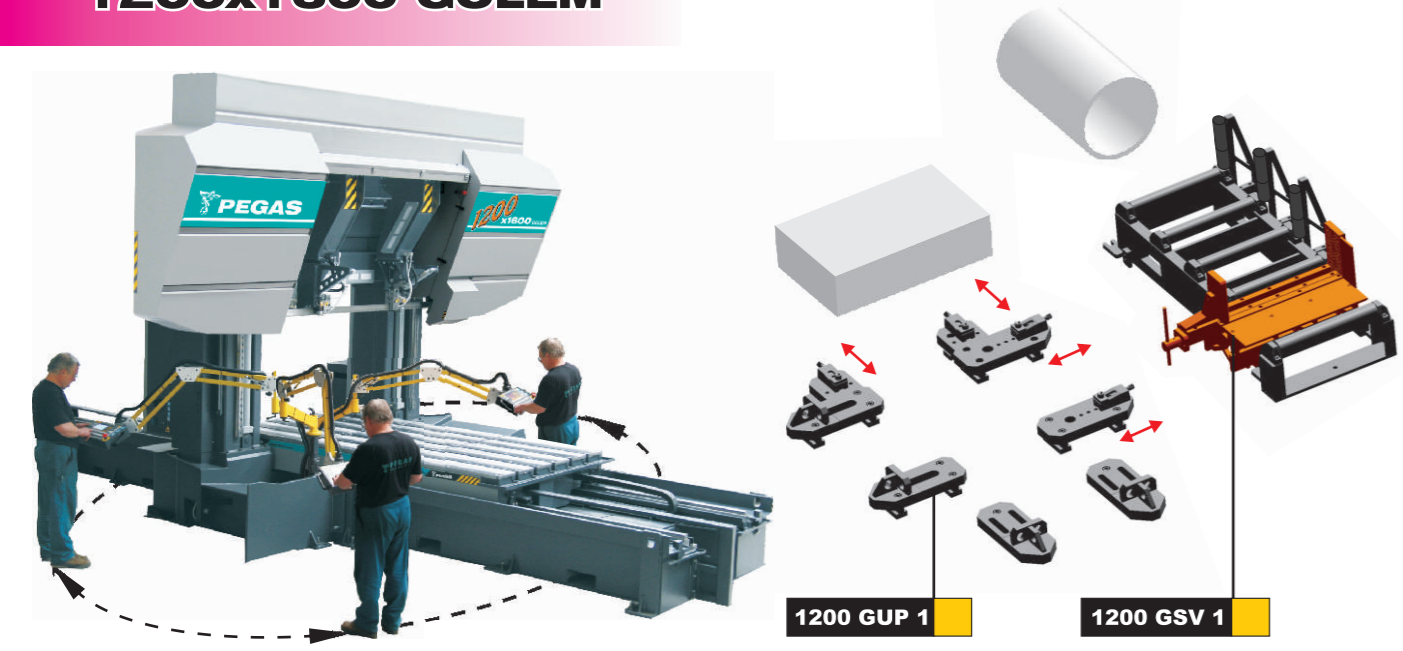

## HERKULES X

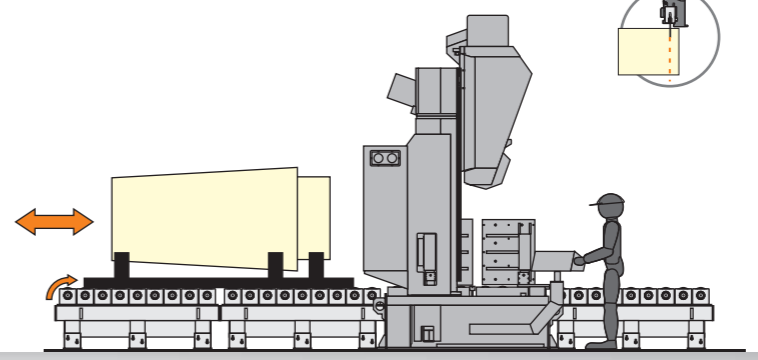

## GOLEM

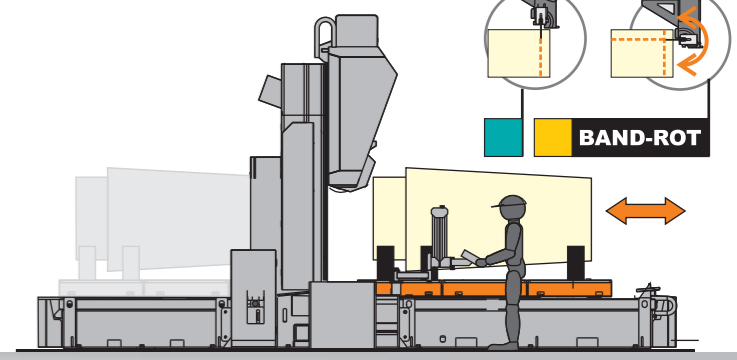

## PORTAL

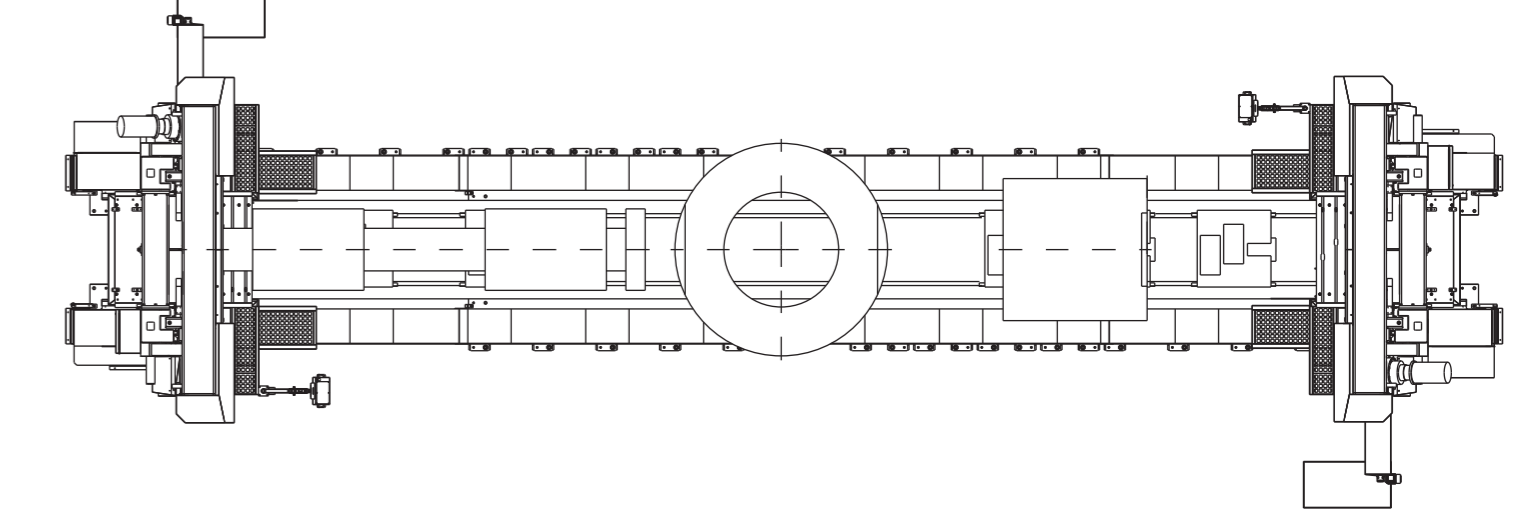
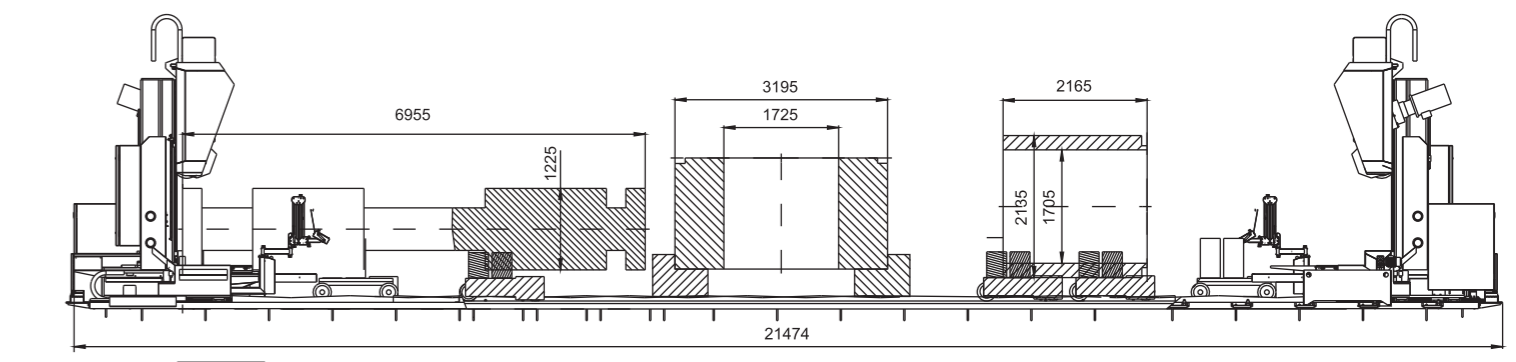
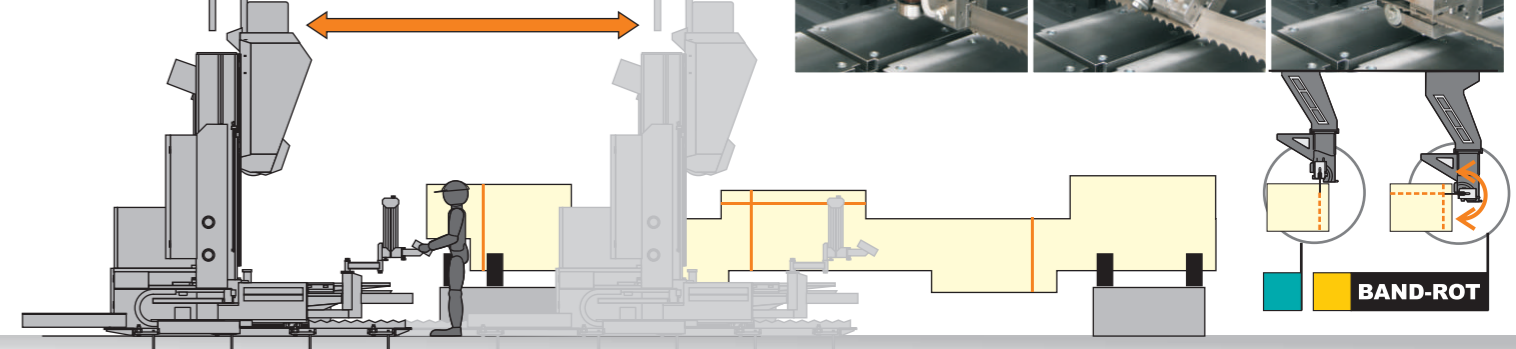

STANDARD OPTION

**PEGAS GONDA**  
 PÍLY NA KOV - BAND SAW MACHINES  
 PEGAS-GONDA s.r.o., Čs. armády 322, 684 01 Slavkov u Brna  
 Tel: 00420-544 221 125, 00420-544 221 126, fax: 00420 544 227 389  
 E-mail: pegas@gonda.cz, www.pegas-gonda.cz, Czech Republic

- výrobce si vyhrazuje právo provádět změny technických údajů, technické údaje odpovídají 1.9.2011  
 /producer has the right to make changes of technical data, technical data are valid on 1.9.2011/  
 - píla na fotografiích není vždy v základním provedení / the machine in the picture is not always in the basic version  
 - uvedené rozměry odpovídají stroji v základním provedení / mentioned diameters are for machine in basic version /

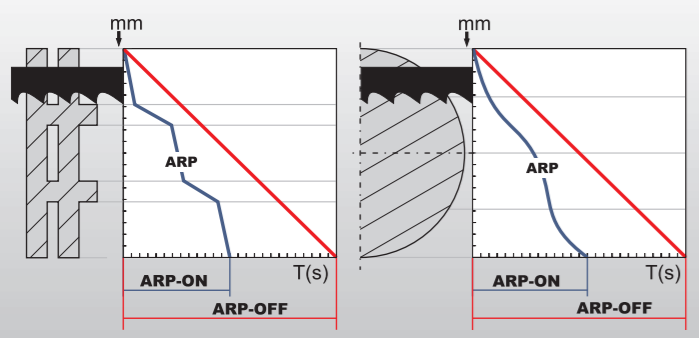

**PEGAS**  
**1200x1400 HERKULES X**

**PEGAS**  
**1250x1600 PORTAL**

**PEGAS**  
**1200x1600 GOLEM**



1200	1200*	1400x1200	1200x800	●
3x400V 50 Hz	11,0	15-80	11650x80x1,6 25 000	

**1200x1400 HERKULES X**

L	5200
L <sub>2</sub>	6300
B	2350
H <sub>min</sub>	2850
H <sub>max</sub>	4000
V	800

1250	1600x1250	1600x ...		●
3x400V 50 Hz	11,0	15-80	11650x80x1,6 20 000	

**1250x1600 PORTAL**

L	5200
B	3550
H <sub>min</sub>	3460
H <sub>max</sub>	4065
V	820

1200	1600x1200	1600x3000		●
3x400V 50 Hz	11,0	15-80	11650x80x1,6 11650x(67)x1,6 30 350	

**1200x1600 GOLEM**

L	5200
H <sub>min</sub>	2850
H <sub>max</sub>	4000
V	800
B <sub>1</sub>	2223
B <sub>2</sub>	2250
B <sub>3</sub>	3180
B	7653