

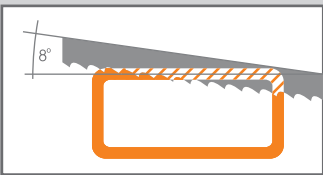

1000 CAMEL X-CNC
1000 CAMEL X

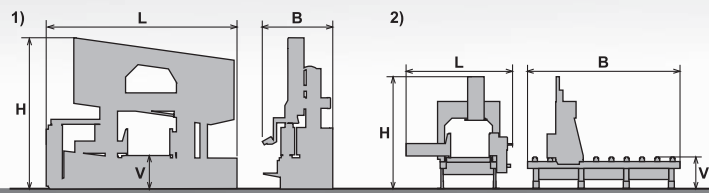

150x200 | 220x250 | 240x280 | 250x315 | 290x290 | 290x320 | 350x400 | 360x500 | 360x600 | 400x400 | 440x600 | 460x600 | 500x750 | 510x510 | 600 CAMEL | 600x750 | 600x1100 | 850x1000 | 1000 CAMEL | 1200x1400



1000	550*	1000x960	1000x650

*doporučené hodnoty / recommended values

●	3x400V 50 Hz	7,5	20-100	8920x54x1,6	

	L	B	Hmin	Hmax	V	kg
1)	4680	1660	2960	3700	815	6040
2)	2250	5400	2700	3010	815 +/-30	3360



PEGAS

1000 CAMEL X-CNC

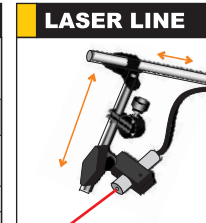
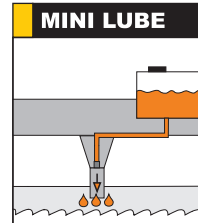
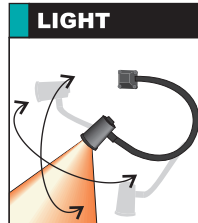
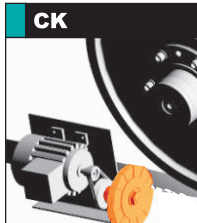

1000 RBRS IMPUT

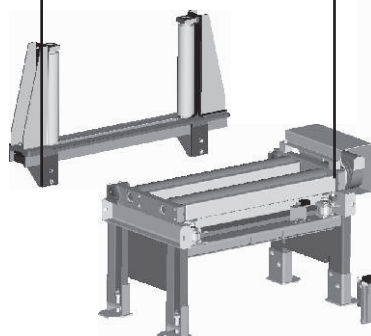

1000 VZM

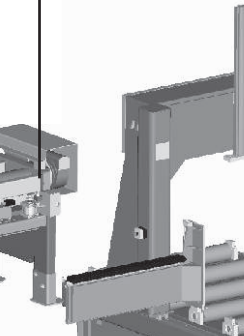

1000 HP-A

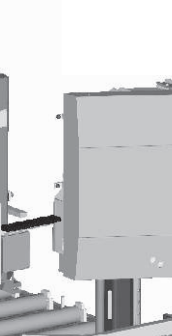

BOX-TAH



BOX-TRI



VTH

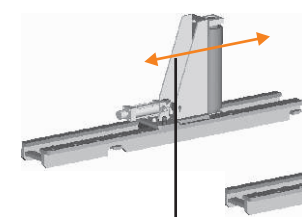

1000 RBRS-H

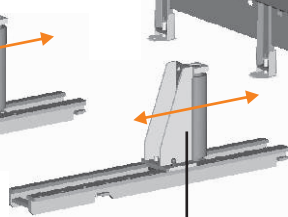

1000 RBRS

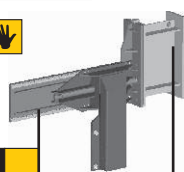

1000 SRZ

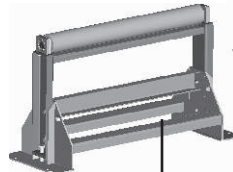

1000 SRH

1000 RDH

1000 RDT 2000/1150

1000 RDT 1000/1150

OPTION

1000 RBR

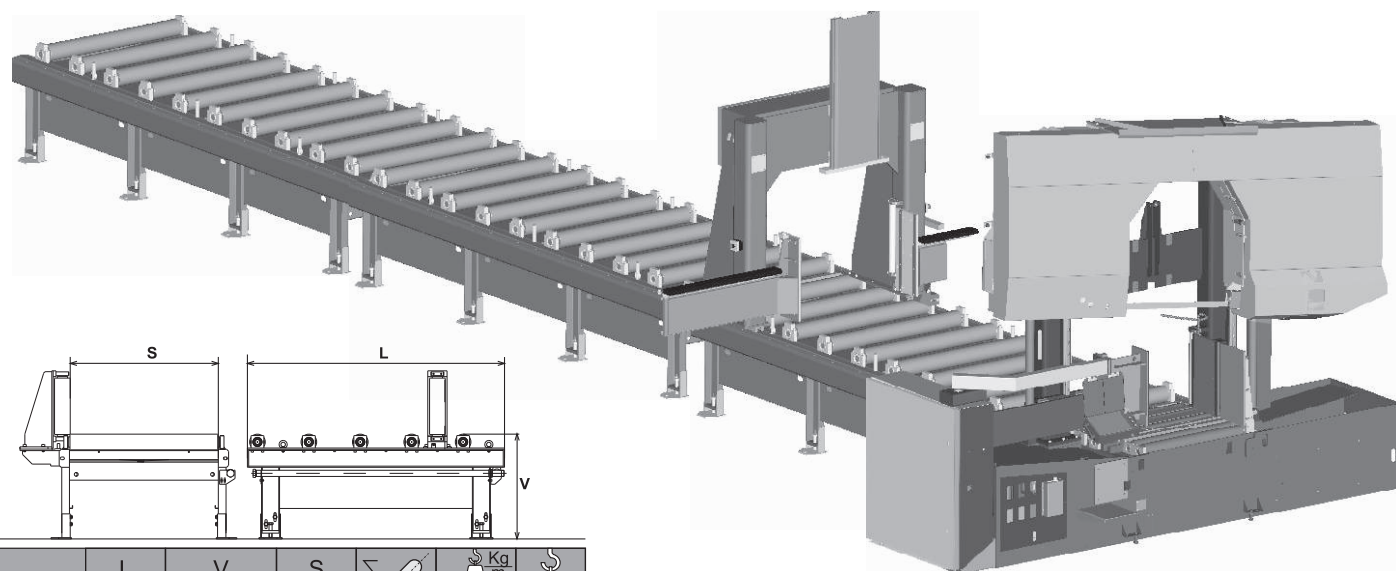

1000 CAMEL X-CNC-12M

	L [mm]	V [mm]	S [mm]		Kg	kg
RDT 1000	1000	815+/-30	1150	3	2000	-
RDT 2000	2000	815+/-30	1150	5	2000	525

■ STANDARD ■ OPTION



PEGAS-GONDA s.r.o, Čs. armády 322, 684 01 Slavkov u Brna
Tel: 00420-544 221 125, 00420-544 221 126, fax: 00420 544 227 389
E-mail: pegas@gonda.cz, www.pegas-gonda.cz, Czech Republic

- výrobce si vyhrazuje právo provádět změny technických údajů, technické údaje odpovídají 1.9.2012
/producer has the right to make changes of technical data, technical data are valid on 1.9.2012/
- píla na fotografii není vždy v základním provedení /the machine in the picture is not always in the basic version
- uvedené rozměry odpovídají stroji v základním provedení /mentioned diameters are for machine in basic version/